

## ACTIVE Shuttle

## Crate Lifting Device

### TAKES CRATES TO A WHOLE NEW LEVEL

Introducing our innovative crate lifting device, designed to complement the ACTIVE Shuttle system. The ACTIVE Shuttle is an advanced Autonomous Mobile Robot (AMR) capable of transporting small load carriers / dollies. Our crate lifting device enhances the functionality of the ACTIVE Shuttle by allowing crates to be elevated to the desired height. This feature significantly improves ergonomics, ensuring safer and more efficient loading and unloading of dollies. The integration of the crate lifting device with the ACTIVE Shuttle system optimizes workflow, reduces physical strain on workers, and enhances overall productivity in your operations. It is designed for easy operation and maximum reliability.

### Advantages at a glance



Capable of lifting crates to various heights as needed.



Seamless integration with the ACTIVE Shuttle system.



Safe and efficient loading and unloading of dollies.



Enhanced productivity and workflow optimization.



Improved ergonomics for workers.



Reduced physical strain on employees and process automation.

## Components



The Bosch Rexroth ACTIVE Shuttle is capable of transporting small load carriers / dollies



From the base plate, entry rail, entry lock, guide rails, roll-out lock to the lifting device, everything is available as a Bosch Rexroth Solution Set



ROKIT Locator is a smart localization software and ROKIT Navigator is an innovative and future-proof VDA5050 compatible solution for precise and efficient motion planning



VDA 5050 compatible control systems such as the ACTIVE Fleet Manager (AFM) of Bosch Rexroth offer comprehensive software for fleet and order control

## Sideload Application

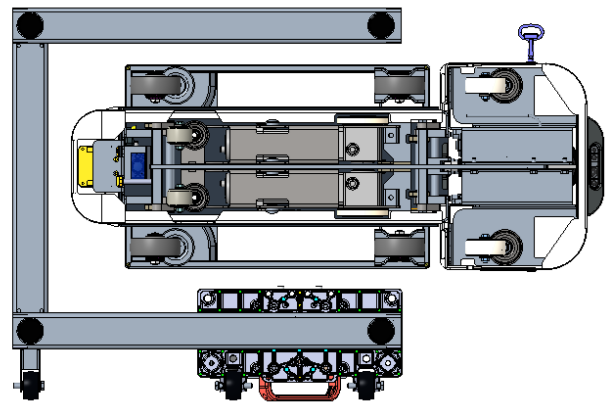
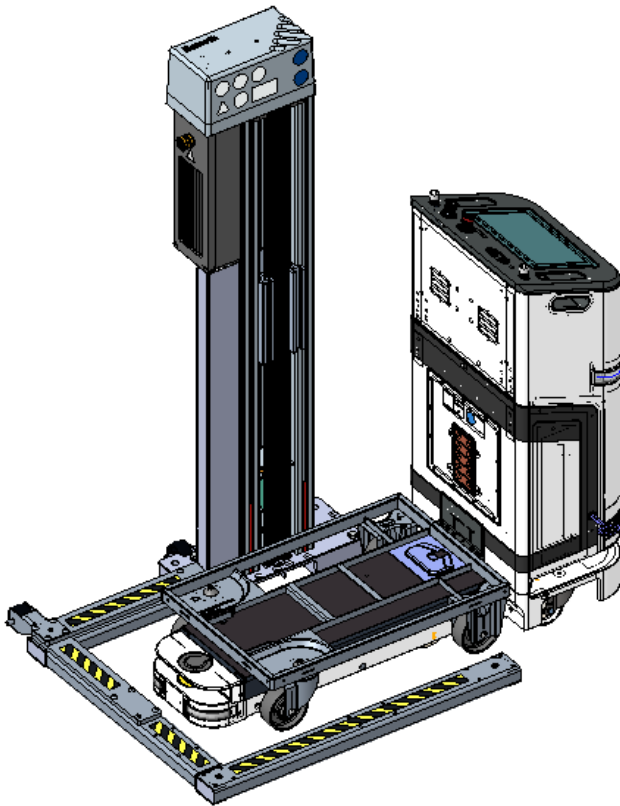

## Contact

**Joerg Willburger**  
DC-AT/ESP1  
[Joerg.Willburger@boschrexroth.de](mailto:Joerg.Willburger@boschrexroth.de)